

Panasonic®

Heavy Duty MP3 CD player/weather Band Receiver
with CD changer Control/Satellite Radio Ready

CQ-5302U



Operating Instructions



MP3



SIRIUS
READY



- Please read these instructions (including “Limited Warranty” and “Customer Services Directory”) carefully before using this product and keep this manual for future reference.

Safety Information

- Read the operating instructions for the unit and all other components of your car audio system carefully before using the system. They contain instructions about how to use the system in a safe and effective manner. Panasonic assumes no responsibility for any problems resulting from failure to observe the instructions given in this manual.



Warning

This pictograph intends to alert you to the presence of important operating instructions and installation instructions. Failure to heed the instructions may result in severe injury or death.



Caution

This pictograph intends to alert you to the presence of important operating instructions and installation instructions. Failure to heed the instructions may result in injury or material damage.



Warning

Observe the following warnings when handling this unit.

- The driver should not operate the system while driving.**
Operating the system will distract the driver from looking ahead of the vehicle and can cause accidents. Always stop the vehicle in a safe location and use the parking brake before operating the system.
- Use the proper power supply.**
This product is designed for operation with a negative grounded 12 V DC battery system. Never operate this product with other battery systems, especially a 24 V DC battery system.
- Do not expose the unit to direct sunlight or excessive heat.**
Otherwise these will raise the interior temperature of the unit, and it may lead to smoke, fire, or other damage to the unit.
- Do not use the product where it is exposed to water, moisture, or dust.**
Exposure of the unit to water, moisture, or dust may lead to smoke, fire, or other damage to the unit. Make especially sure that the unit does not get wet in car washes or on rainy days.
- Protect the Deck Mechanism.**
Do not insert any foreign objects into the slot of this unit.
- Do not disassemble or modify the unit.**
Do not disassemble, modify the unit or attempt to repair the product yourself. If the product needs to be repaired, consult the shop where you purchased this unit or an authorized Panasonic Servicer.
- Do not use the unit when it is out of order.**
If the unit is out of order (no power, no sound) or in an abnormal state (has foreign matter in it, is exposed to water, is smoking, or smells), turn it off immediately and consult the store where you purchased it.
- Any NOAA broadcast weather report, including current and forecasts, may not reflect your actual weather conditions at your exact time and location. You should always pay attention to your actual weather conditions to make safe decisions accordingly.**

Observe the following warnings when installation.

- Disconnect the lead from the negative (-) battery terminal before installation.**
Wiring and installation with the negative (-) battery terminal connected may cause electrical shock and injury due to a short circuit.
Some cars equipped with the electrical safety system have specific procedures of battery terminal disconnection.
FAILURE TO FOLLOW THE PROCEDURE MAY LEAD TO THE UNINTENDED ACTIVATION OF THE ELECTRICAL SAFETY SYSTEM RESULTING IN DAMAGE TO THE VEHICLE AND PERSONAL INJURY OR DEATH.
- Never use safety-related components for installation, grounding, and other such functions.**
Do not use safety-related vehicle components (fuel tank, brake, suspension, steering wheel, pedals, airbag, etc.) for wiring or fixing the product or its accessories.
- Installing the product on the air bag cover or in a location where it interferes with airbag operation is prohibited.**
- Check for piping, gasoline tank, electric wiring, and other items before installing the product.**
If you need to open a hole in the vehicle chassis to attach or wire the product, first check where the wire harness, gasoline tank, and electric wiring are located. Then open the hole from outside if possible.
- Never install the product in a location where it interferes with your field of vision.**
- Never have the power cord branched to supply other equipment with power.**
- After installation and wiring, you should check the normal operation of other electrical equipment.**
The continuation of their using in abnormal conditions may cause fire, electrical shock or a traffic accident.
- In the case of installation to an airbag-equipping car, confirm warnings and cautions of the vehicle manufacturer before installation.**
- Make sure the leads do not interfere with driving or getting in and out of the vehicle.**
- Insulate all exposed wires to prevent short circuiting.**
- This unit should be used with the power supply by a 10 A fuse. Failure to heed this may lead to smoke, fire and damage to the unit.**

Caution

Observe the following cautions when handling this unit.

- Keep the sound volume at an appropriate level.**
Keep the volume level low enough to be aware of road and traffic conditions while driving.
- Do not insert or allow your hand or fingers to be caught in the unit.**
To prevent injury, do not get your hand or fingers caught in moving parts or in the disc slot. Especially watch out for infants.
- This unit is designed for use exclusively in automobiles.**
- Do not operate the unit for a prolonged period with the engine turned off.**
Operating the audio system for a long period of time with the engine turned off will drain the battery.
- Refer fuse replacement to qualified service personnel.**
When the fuse burns out, eliminate the cause and have it replaced with the fuse prescribed for this unit by a qualified service engineer. Incorrect replacement of the fuse may lead to smoke, fire, and damage to the product.
- To ensure safety, never attempt to preset stations while you are driving.**
- Depending upon the transmission condition of electro-magnetic waves, the geographical reasons and/or the weather conditions, you may not receive the NOAA radio partially or at all.**
- Make sure that your weather radio can receive properly before driving, especially, before use in a critical condition.**

Observe the following cautions when installation.

- Refer wiring and installation to qualified service personnel.**
Installation of this unit requires special skills and experience. For maximum safety, have it installed by the shop where you purchased it. Panasonic is not liable for any problems resulting from your own installation of the unit.

- Follow the instruction to install and wire the product.**

Not following the instructions to properly install and wire the product could cause an accident or fire.

- Take care not to damage the leads.**
When wiring, take care not to damage the leads. Prevent them from getting caught in the vehicle chassis, screws, and moving parts such as seat rails. Do not scratch, pull, bend or twist the leads. Do not run them near heat sources or place heavy objects on them. If leads must be run over sharp metal edges, protect the leads by winding them with vinyl tape or similar protection.
- Use the designated parts and tools for installation.**
Use the supplied or designated parts and appropriate tools to install the product. The use of parts other than those supplied or designated may result in internal damage to the unit. Faulty installation may lead to an accident, a malfunction or fire.
- Do not block the air vent or the cooling plate of the unit.**
Blocking these parts will cause the interior of the unit to overheat and will result in fire or other damage.
- Do not install the product where it is exposed to strong vibrations or is unstable.**
Avoid slanted or strongly curved surfaces for installation. If the installation is not stable, the unit may fall down while driving and this can lead to an accident or injury.
- Installation Angle**
The product should be installed in a horizontal position with the front end up at a convenient angle, but not more than 30°. The user should bear in mind that in some areas there may be restrictions on how and where this unit must be installed. Consult your dealer for further details.
- Wear gloves for safety. Make sure that wiring is completed before installation.**
- To prevent damage to the unit, do not connect the power connector until the whole wiring is completed.**
- Do not connect more than one speaker to one set of speaker leads. (except for connecting to a tweeter)**

Caution

**THIS PRODUCT UTILIZES A CLASS I LASER.
USE OF CONTROLS OR ADJUSTMENTS OR PERFORMANCE OF
PROCEDURES OTHER THAN THOSE SPECIFIED HEREIN MAY
RESULT IN HAZARDOUS RADIATION EXPOSURE.
DO NOT OPEN COVERS AND DO NOT REPAIR YOURSELF.
REFER SERVICING TO QUALIFIED PERSONNEL.**

Find the model number and serial number on either the back or bottom of the unit. Please record them in the space below and retain this booklet as a permanent record of your purchase to help with identification in case of theft.

MODEL NUMBER CQ-5302U SERIAL NUMBER _____
DATE PURCHASED _____ FROM _____

Safety Information (Continued)

Warning

TO REDUCE THE RISK OF FIRE OR ELECTRIC SHOCK OR PRODUCT DAMAGE, DO NOT EXPOSE THIS APPLIANCE TO RAIN, SPLASHING, DRIPPING OR MOISTURE.

Caution

PLEASE FOLLOW THE LAWS AND REGULATIONS OF YOUR STATE, PROVINCE OR COUNTRY FOR INSTALLATION OF THE UNIT.

Laser Products:

Wave length: 790 nm

Laser power: No hazardous radiation is emitted with safety protection.

TO REDUCE THE RISK OF FIRE OR ELECTRIC SHOCK, AND ANNOYING INTERFERENCE, USE ONLY THE INCLUDED COMPONENTS.

The following applies only in the U.S.A.

Part 15 of the FCC Rules

FCC Warning:

Any unauthorized changes or modifications to this equipment would void the user's authority to operate this device.

Warning

ANY NOAA BROADCAST WEATHER REPORT, INCLUDING CURRENT AND FORECASTS, MAY NOT REFLECT YOUR ACTUAL WEATHER CONDITIONS AT YOUR EXACT TIME AND LOCATION. YOU SHOULD ALWAYS PAY ATTENTION TO YOUR ACTUAL WEATHER CONDITIONS TO MAKE SAFE DECISIONS ACCORDINGLY.

ANTI-SHOCK Protection (CD/MP3 Player)

This unit has the anti-shock memory for about 8 seconds to prevent sound skips due to vibration on unstable roads.

Panasonic welcomes you to our ever growing family of electronic product owners. We know that this product will bring you many hours of enjoyment. Our reputation is built on precise electronic and mechanical engineering, manufactured with carefully selected components and assembled by people who take pride in their work. Once you discover the quality, reliability, and value we have built into this product, you too will be proud to be a member of our family.

Accessories

1. Operating Instructions1
2. Supplied Hardware.....1 set (⇒ page 44)

Customer services Directory

U.S.A.

Obtain Product Information and Operating Assistance; locate your nearest Dealer or Servicenter; purchase Parts and Accessories; or make Customer Service and Literature requests by visiting our Web Site at:

<http://www.panasonic.com/support>

or, contact us via the web at:

<http://www.panasonic.com/contactinfo>

You may also contact us directly at:

1-800-211-PANA (7262),

Monday-Friday 9 am-9 pm; Saturday-Sunday 10 am-7 pm, EST.

For hearing or speech impaired TTY users,
TTY: 1-877-833-8855

Accessory Purchases:

Purchase Parts, Accessories and Instruction Books online for all Panasonic Products by visiting our Web Site at:

<http://www.pasc.panasonic.com>

or, send your request by E-mail to:

npcparts@panasonic.com

You may also contact us directly at:

1-800-332-5368 (Phone) 1-800-237-9080 (Fax Only)

(Monday-Friday 9 am to 8 pm, EST.)

Panasonic Services Company

20421 84th Avenue South, Kent, WA 98032

(We accept Visa, masterCard, discover Card, American Express, and Personal checks)

For hearing or speech impaired TTY users,
TTY: 1-866-605-1277

Service in Puer to Rico

Panasonic Puerto Rico, Inc.

Panasonic Sales Company

Factory Servicenter:

Ave. 65 de Infanteria, Km. 9.5, San Gabriel Industrial Park, Carolina, Puerto Rico 00985

Phone (787) 750-4300, fax (787) 768-2910

Limited Warranty

U.S.A.

PANASONIC CONSUMER ELECTRONICS COMPANY,
DIVISION OF PANASONIC CORPORATION OF NORTH AMERICA
One Panasonic Way, Secaucus, New Jersey 07094

PANASONIC SALES COMPANY,
DIVISION OF PANASONIC PUERTO RICO, INC.
Ave. 65 de infanteria, Km. 9.5, San Gabriel Industrial park
Carolina, Puerto Rico 00985

PANASONIC AUTO PRODUCTS LIMITED WARRANTY

LIMITED WARRANTY COVERAGE

If your product does not work properly because of defects in materials and workmanship.

Panasonic consumer Electronics Company or Panasonic Sales Company (collectively referred to as "the warrantor") will, for the length of the period indicated in the chart below, which starts with the date of original purchase ("warranty period"), at its option either (a) repair your product with new or refurbished parts, or (b) replace it with a new or refurbished product. The decision to repair or replace will be made by the warrantor.

Categories	Parts	Labor
Audio Components (except items listed below)	one (1) Year	One (1) year
MXE Series Audio components (except items listed below)	Two (2) Years	Two (2) Years
Speakers	One (1) Year	Not Applicable
Accessories (in exchange for defective items)	Ninety (90) Days	Not Applicable

During the "Labor" warranty period, there will be no charge for labor. during the "Parts" warranty period, there will be no charge for parts. You must carry in or mail in your product during the warranty period. If non-rechargeable batteries are included, they are not warranted. This warranty only applies to products purchased and serviced in the United States or Puerto rico. This warranty is extended only to the original purchaser of a new product which was not sold "as is". A purchase receipt or other proof of the original purchase date is required for warranty service.

CARRY-IN OR MAIL-IN SERVICE

For Carry-In or Mail-In service in the United States, call 1-800-211-PANA (7262) or visit
Panasonic Web Site: <http://www.panasonic.com>
For assistance in Puerto rico, call Panasonic Sales company (787)-750-4300 or fax (787)-768-2910.

LIMITED WARRANTY LIMITS AND EXCLUSIONS

This warranty ONLY COVERS failures due to defects in materials and workmanship, and DOES NOT COVER normal wear and tear or cosmetic damage. The warranty ALSO DOES NOT COVER damages which occurred during shipment, failures which are caused by

products not supplied by the warrantor, failures which result from accident, misuse, abuse, neglect, mishandling, misapplication, alteration, faulty installation, set-up adjustment, maladjustment of consumer control, improper maintenance, improper antenna, inadequate signal reception or pickup, power line surge, improper voltage supply, lightning, modification, commercial use (such as use in hotels, offices, restaurants, or other business uses) or rental use of the product, or service by anyone other than the technician from Factory Servicenter or other authorized service centers, or damage that is attributable to acts of God.

THERE ARE NO EXPRESS WARRANTIES EXCEPT AS LISTED UNDER "LIMITED WARRANTY COVERAGE". THE WARRANTOR IS NOT LIABLE FOR INCIDENTAL OR CONSEQUENTIAL DAMAGES RESULTING FROM THE USE OF THIS PRODUCT, OR ARISING OUT OF ANY BREACH OF THIS WARRANTY.

(As examples, this excludes damages for lost time, cost of having someone remove or re-install an installed unit if applicable, travel to and from the servicer, and loss of media, data or other memory contents. The items listed are not exclusive, but are for illustration only.) **ALL EXPRESS AND IMPLIED WARRANTIES, INCLUDING THE WARRANTY OF MERCHANTABILITY, ARE LIMITED TO THE PERIOD OF THE LIMITED WARRANTY.**

Some states do not allow the exclusion or limitation of incidental or consequential damages, or limitations on how long an implied warranty lasts, so the exclusions may not apply to you.

This warranty gives you specific legal rights and you may also have other rights which vary from state to state. If a problem with this product develops during or after the warranty period, you may contact your dealer or Servicenter. If the problem is not handled to your satisfaction, then write to warrantor's consumer Affairs Department at the addresses of the warrantor.

PARTS AND SERVICE WHICH ARE NOT COVERED BY THIS LIMITED WARRANTY ARE YOUR RESPONSIBILITY.

Customer's Record

Model
No.

Serial
No.

Dealer's
No.

Code
No.

Dealer's
Address

Date of
Purchase

Connectable Devices

CD Changer

You can connect the optional Panasonic CD changer unit (CX-DP880). For details, refer to the operating instructions for the CD changer unit. (⇒ page 20)

XM Satellite Radio

You can connect the optional XM receiver (XM-RVR-FM-001) with optional Digital Adapter. For details, refer to the operating instructions for the XM receiver.

(⇒ page 22)

About XM

The direct satellite-to-receiver broadcasting technology is used to provide listeners with crystal clear sound smoothly from coast to coast. XM is over 130 channels of sheer variety: digital-quality music, news, sports, comedy, traffic & weather, talk, children's programs, and more.

The XM name and related logos are trademarks of XM Satellite Radio Inc.

Sirius Satellite Radio









You can connect the optional Sirius Satellite radio receiver (SIR-PAN1). (⇒ page 26)

Sirius Satellite Broadcast service

The Sirius Satellite coverage is only for the United States except Hawaii and Alaska. There is no Sirius Satellite coverage in Canada. The instruction of Satellite Operation Controls in the Operating Instructions and Guide will not be applied.

© SIRIUS Satellite Radio Inc. "SIRIUS" and related marks are trademarks of SIRIUS Satellite Radio Inc.

Contents

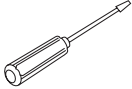
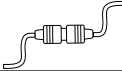
Safety Information (Part 15 of the FCC Rules)	Page 2	
ANTI-SHOCK Protection (CD/MP3 Player)	4	
Accessories	4	
Customer Services Directory	5	
Limited Warranty	6	
Connectable Devices	7	
Contents	8	
<hr/>		
<input type="checkbox"/> Power and Sound Controls	9	
Power, volume, mute, display change, SQ setting, audio modes (Bass/Treble/Balance/Fader)		
<hr/>		
<input type="checkbox"/> Clock Adjustment	12	
Initial time, time readjustment		
<hr/>		
<input type="checkbox"/> Radio	13	
Radio mode, band, manual tuning, seek tuning, preset station setting, preset station calling, Weather Band Stations		
<hr/>		
<input type="checkbox"/> CD/MP3 Player	16	
Operation flow, Player source display, random play, random repeat play, repeat play, scan play		
<hr/>		
<input type="checkbox"/> CD changer control	20	
CD Changer mode, Disc Selection, Track Selection, Track Search, scan play, repeat play, random play, random repeat play Note: CD changer controls are applicable to units with optional CD changer unit (sold separately)		
<hr/>		
<input type="checkbox"/> XM Control	22	
Getting Started, XM Mode, Band, Channel Selection, Category Priority Setting and Selecting, Manual Preset Memory, Preset Memory Calling, Display Change, XM ID Confirmation, Error display		
<hr/>		
<input type="checkbox"/> Sirius Control	26	
Sirius mode, Band, Channel Selection, Category Priority Setting and Selecting, Manual Preset Memory, Preset Memory Calling, Display Change, Sirius ID confirmation, System Control Mode (Parental Channel Lock/Unlock setting, RADIO ID), Pass Code Change/Setting, Error display		
<hr/>		
<input type="checkbox"/> Troubleshooting	34	
Troubleshooting tips, Error Display Messages		
<hr/>		
<input type="checkbox"/> Maintenance	39	
Care of the unit, notes on discs, notes on CD-Rs/RWs, notes on MP3		
<hr/>		
<input type="checkbox"/> Speaker Connections	42	
<hr/>		
<input type="checkbox"/> Installation Guide	43	
Installation hardware, overview, required tools, dashboard specifications, preparation, to remove the unit		
<hr/>		
<input type="checkbox"/> Electrical Connections	47	
Cautions, wiring diagram		
<hr/>		
<input type="checkbox"/> Specifications	51	

Power and Sound Controls

Power

Turn the key in the ignition until the accessory indicator lights.

Power on: Press [SRC](POWER).

Power off: Hold down [SRC](POWER) for more than 1 second.

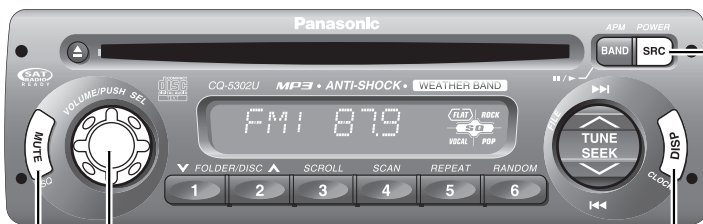

Volume

Turn the knob clockwise to increase volume, and counterclockwise to decrease volume.



Volume level (0 to 40)
(default:18)

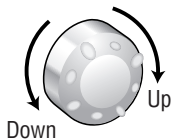

Display Change

Press [DISP] to switch to the clock display.

When the power is off:



clock display (default) No display

Note: "ADJUST" is displayed when the clock is not adjusted. (⇒ page 12)

Mute

Press [MUTE] to mute the sound completely.



Press [MUTE] again to cancel.

Power and Sound Controls (Continued)

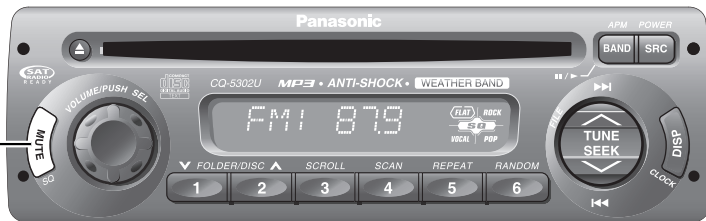

SQ (Sound Quality)

SQ is a function that can call up various sound types at the touch of button in accordance with your listening music type.

Press **[SQ]** for more than 2 seconds to select the sound type as follows:

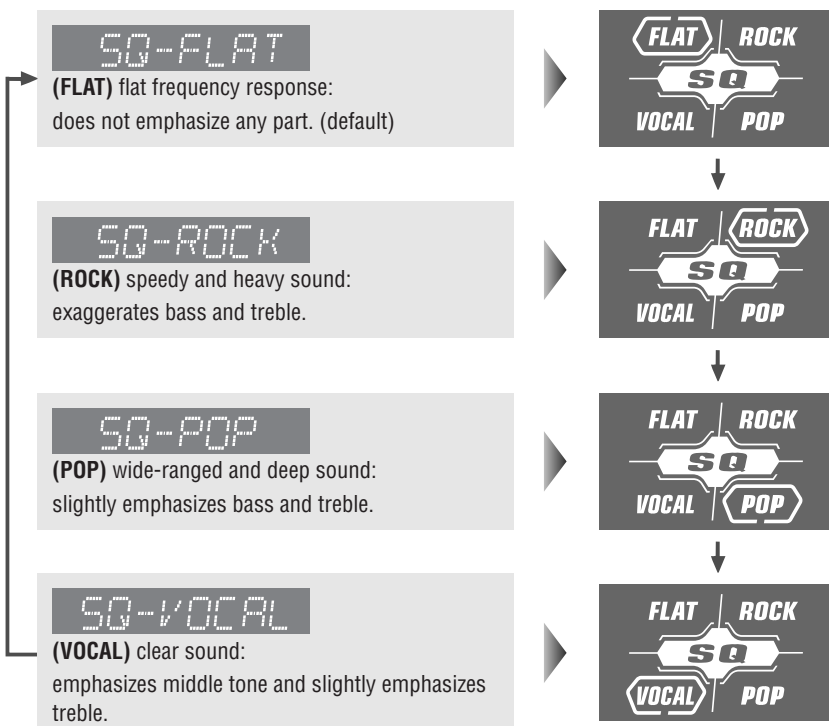

Note: Settings of SQ, bass and treble are influenced one another. If such an influence causes distortion to the audio signal, readjust bass/treble or volume.

Audio Modes (Bass/Treble/Balance/Fader)

Note: If no operation takes place for more than 5 seconds in audio mode (2 seconds in volume mode), the display returns to the regular mode.

1 Push [SEL] to select the audio mode.

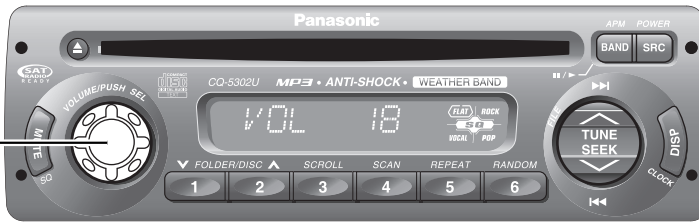
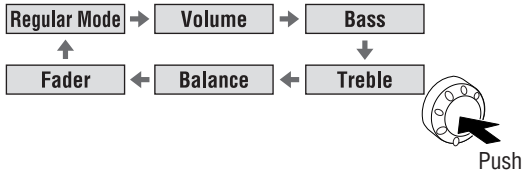

2 Turn [VOL] (volume) clockwise or counterclockwise to change each level.

VOL 18 **Volume**
(Setting Range: 0 to 40, Default: 18)

VOL 20

① : UP
② : Down

BASS **Bass**
(Setting Range: -12 dB to +12 dB by 2 dB, Default: 0 dB)

BAS+ 6dB

① : Increased
② : Decreased

TREBLE **Treble**
(Setting Range: -12 dB to +12 dB by 2 dB, Default: 0 dB)

TRE+ 6dB

① : Increased
② : Decreased

BALANCE **Balance**
(Setting Range: 15 levels each and 0 (center), Default: CNT)

BAL L 15

① : Right enhanced
② : Left enhanced

FADER **Fader**
(Setting Range: 15 levels each and 0 (center), Default: CNT)

FAD F 15

① : Front enhanced
② : Rear enhanced

Clock Adjustment

Selecting the Clock Display

Press [DISP] to change the display.

Radio mode display (default)

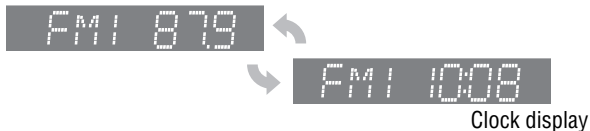

The 12-hour system is used for the clock.

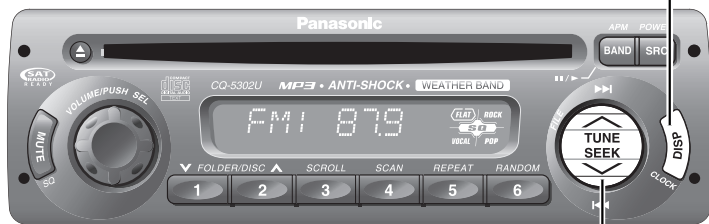

[V TUNE], [^ TUNE]
(Hours, Minutes)

Initial Time

- 1 Press [DISP] (CLOCK).



- 2 Hold down [DISP] (CLOCK) for more than 2 seconds.



- 3 Adjust the hour.



Press [^]: sets the hour ahead.
Press [V]: sets the hour back.

- 4 Press [DISP] (CLOCK).



- 5 Adjust the minute.



Press [^]: sets the minute ahead.
Press [V]: sets the minute back.

- 6 Press [DISP] (CLOCK).



Time Readjustment

When you want to readjust the time, repeat steps ② to ⑥.

Note: Hold down [V] or [^] to change numbers rapidly.

Radio

① Radio Mode

Press [SRC] to change to the radio mode.

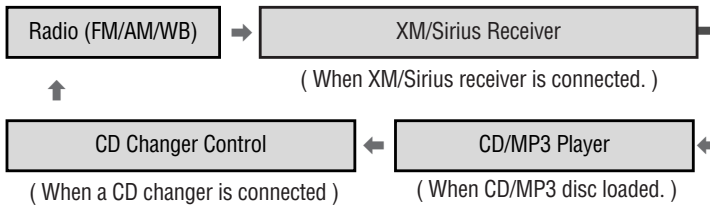

② Band

Press [BAND] to change the band.

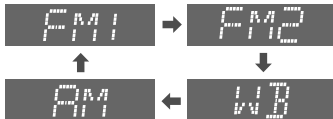

FM stereo indicator, lights while receiving an FM stereo signal.

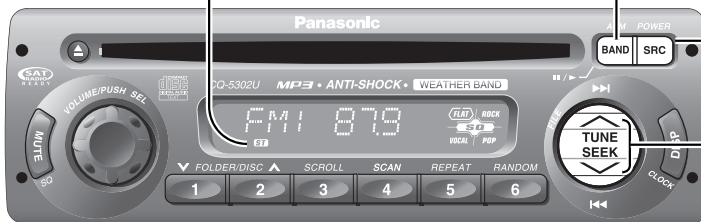

③ Manual Tuning

[\wedge TUNE]: Higher frequency

[\vee TUNE]: Lower frequency

Seek Tuning

Press and hold for more than 0.5 seconds and release it.

[\wedge SEEK]: Higher frequency

[\vee SEEK]: Lower frequency

Tuning will automatically stop when the next broadcast station is received.

Radio (Continued)

Preset Station Setting

Up to 6 stations can be saved in each of the FM1, FM2 and AM preset station memories.

Note: Existing saved stations are overwritten with new stations after following this procedure.

① Band

Press **[BAND]** to select a desired band.
(⇒ page 13)

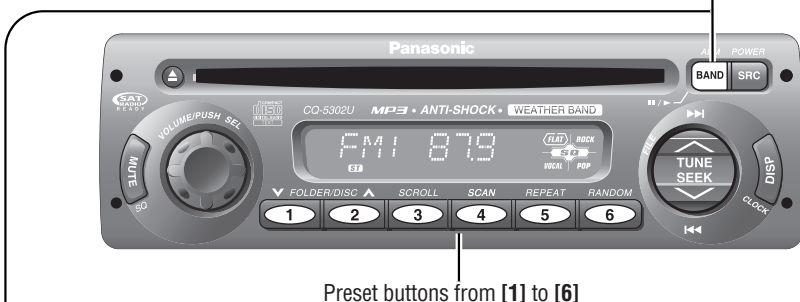

② Auto Preset Memory (APM)

Press and hold **[BAND]** (APM: auto preset memory) for more than 2 seconds.

- The 6 stations with good reception will be automatically saved in the memory under preset buttons from **[1]** to **[6]**.
- Once set, the preset stations are sequentially scanned for 5 seconds each.
- Press **[BAND]** again to stop sequentially scan.

Manual Preset Memory

- ① Use manual or seek tuning to find a station. (⇒ page 13)
- ② Press and hold one of the preset buttons from **[1]** to **[6]** until the display blinks once.

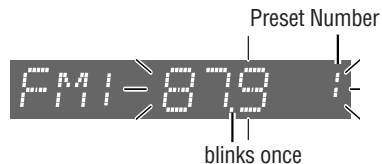

Preset Station Calling

Press the corresponding preset button from **[1]** to **[6]** to tune in a preset station.



Caution

To ensure safety, never attempt to preset stations while you are driving.

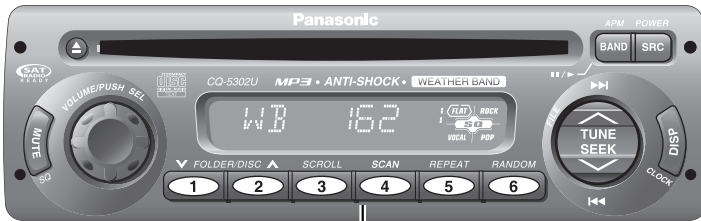

Tuning in a Weather Band Station

- Press **[BAND]** to select WB (Weather Band). (➔ page 13)
- Press any of the buttons **[1]** to **[6]** to monitor the preset station.

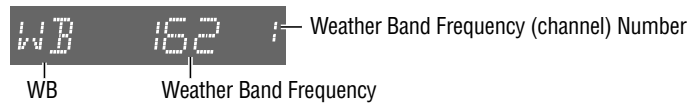

Note: The weather band (CH1-6) has been preset. CH7 is selected by pressing **[^]** or **[v]**.

Weather Band Stations

National Weather Radio Broadcasts from over 380 locations throughout the U.S. on seven VHF/FM frequencies.

Tune to weather band to receive continuous weather information 24 hours a day on one of the following frequencies.

1. 162.550 MHz
2. 162.400 MHz
3. 162.475 MHz
4. 162.425 MHz
5. 165.450 MHz
6. 162.500 MHz
7. 162.525 MHz

Occasionally the frequency of an existing or planned station must be changed because of unexpected radio frequency interfere with adjacent NOAA weather Radio Stations and/or with other Government or commercial Operations within the area. If you have a question concerning NOAA Weather Radio, please contact your nearest National Weather Service Office.

Warning

Any NOAA broadcast weather report, including current and forecasts, may not reflect your actual weather conditions at your exact time and location. You should always pay attention to your actual weather conditions to make safe decisions accordingly.

CD/MP3 Player

Disc slot

takes a disc in with the printed side facing up.

Notes:

- The power will be turned on automatically when a disc is loaded.
- Playback will start automatically after the player recognized the loaded disc as an ordinary music CD or MP3 CD.

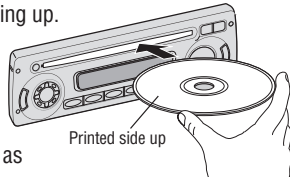

[▲] (eject)
ejects the disc.

[BAND] (|| / ▶) (Pause/Play)
toggles pause/play in the player source.

[SRC] (Source)
Selects a source.

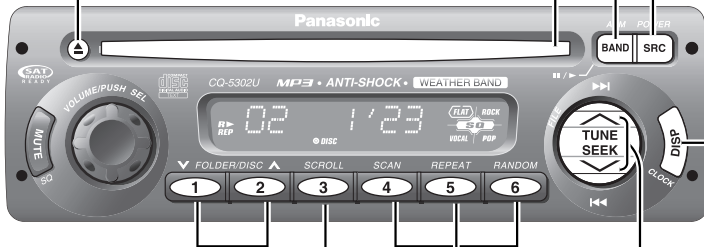

[DISP] (Display)
switches the information on the display.

[1] FOLDER ∨
[2] FOLDER ∧
skip to the previous/next folder in MP3 mode.

[3] (SCROLL)
scrolls the information on display.

[◀◀] [▶▶]
skip to the previous/next track/file in the player mode. Hold down either of them for fast reverse/fast forward.

[4] (SCAN) / [5] (REPEAT) / [6] (RANDOM)
toggles on/off each play mode.

Caution

- Do not insert a disc when the **DISC** indicator lights.
- Refer to the section of “Notes on Discs” and “Notes on MP3.”
- This unit does not support 8 cm {3"} discs.

- If you insert an 8 cm {3"} disc and cannot eject it, turn ACC of your car off once and turn it on again, then press [▲](Eject).
- Do not insert foreign objects into the disc slot.
- This unit does not support WMA disc playback.
- Do not use irregular shaped discs.
- Do not use discs that have a seal or label attached.

Operation Flow

1 Press [**SRC**] to select the Disc Player source.

2 Select a desired portion.

Track/file selection

Press [**◀◀**] / [**▶▶**].

Note: To perform fast forward/reverse, hold down either of them.

Disc Player (CD-DA disc):

Previous/next track

Disc Player (MP3 disc):

Previous/next file

Folder selection (MP3)

Press [**1**] FOLDER **∨** / [**2**] FOLDER **∧**.

Disc Player (MP3 disc):

Previous/next folder

Pause

Press [**BAND**] (**⏸** / **▶**).

Press again to cancel.

Player Source Display

CD-DA mode display

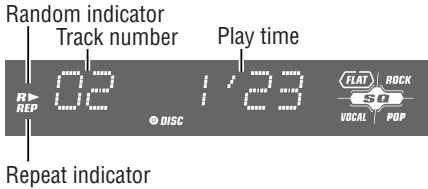

MP3 mode display

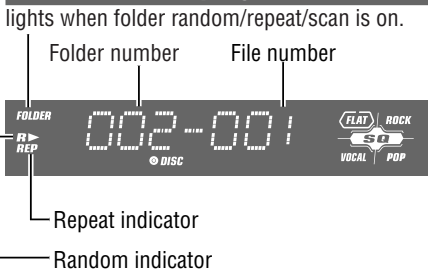

Notes:

- For scrolling text, press [3] (SCROLL).
- "NO TEXT" is displayed when there is no information on the disc.
- This unit can playback a disc that contains both CD-DA files and MP3 files. (Mixed Mode CD)
Press [1] FOLDER ∇ / [2] FOLDER \blacktriangle to switch CD-DA files and MP3 files mode playback in the disc.

Display change

Press [DISP] to change the display.

Disc Player (CD-DA disc):

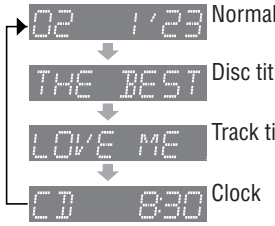

* CD TEXT Display

Disc title and Track title name are displayed.

Disc Player (MP3 disc):

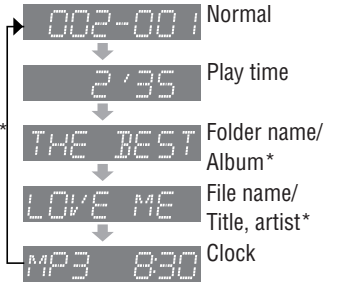

* ID3 Tag ON/OFF

Hold down [3] (SCROLL) for more than 2 seconds.



- album title and song title/artist name are displayed.



(Default)

folder name/file name are displayed.

Random, Repeat, Scan

Random play

All the available tracks/files are played in a random sequence.

Press **[6] (RANDOM)**.

Press again to cancel.

Folder random play (MP3)

All the available files in current folder are played in a random sequence.

Hold down **[6] (RANDOM)** for more than 2 seconds.

Hold down again to cancel.

Random repeat play

All the available tracks/files are played in a random sequence and then repeated the current tracks/files.

Press **[6] (RANDOM)** and then press **[5] (REPEAT)**.

Press **[6] (RANDOM)** again to cancel.

Folder random repeat play (MP3)

All the available files in current folder are played in a random sequence and then repeated the current files.

Hold down **[6] (RANDOM)** for more than 2 seconds and then press **[5] (REPEAT)**.

Hold down **[6] (RANDOM)** for more than 2 seconds to cancel.

Repeat play

The current track/file is repeated.

Press **[5] (REPEAT)**.

Press again to cancel.

Folder repeat play (MP3)

The current folder is repeated.

Hold down **[5] (REPEAT)** for more than 2 seconds.

Hold down again to cancel.

Scan play

The first 10 seconds of each tracks/files is played in sequence.

Press **[4] (SCAN)**.

Press again to cancel.

Folder scan play (MP3)

From the next folder, the first 10 seconds of the first file in each album is played in sequence.

Hold down **[4] (SCAN)** for more than 2 seconds.

Hold down again to cancel.

CD Changer Control

- CD changer functions are designed for optional Panasonic CD changer unit (CX-DP880).

Preparation:

- Connect the CD changer, and load a magazine (CDs).

① CD Changer mode

While a disc magazine is inserted in the CD changer, press **[SRC]** to select CD changer mode. **Play starts from the first track.**

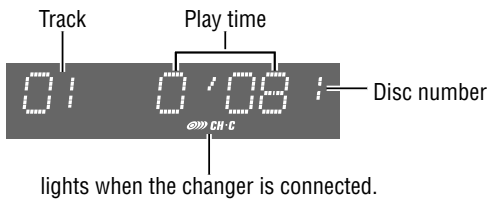

Note:

- Load a magazine with CDs when "NO DISC" is displayed.
- The power will be turned on automatically when a magazine is loaded.

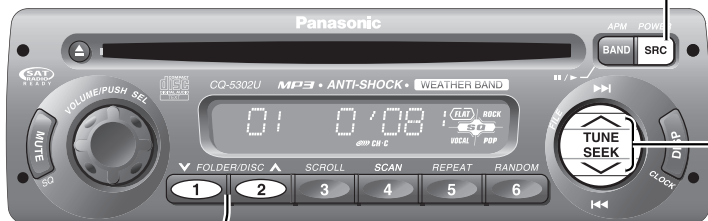

② Disc Selection

- [1] (∨ DISC): Previous disc.
- [2] (∧ DISC): Next disc.

③ Track Selection

Press **[TRACK ►►]** once to go to the next track. Press repeatedly to step forward through all the tracks. Press **[TRACK ◄◄]** once to play from the beginning of the current track, Press twice to play the previous track. Press repeatedly to step backward through all the tracks.

Track Search

Press and hold **[TRACK ►►]** or **[TRACK ◄◄]** for more than 0.5 seconds to activate fast forward or reverse through a track. Release it to resume the normal CD play from that position.

❑ Wired Remote Control

CA-RC330U (option)

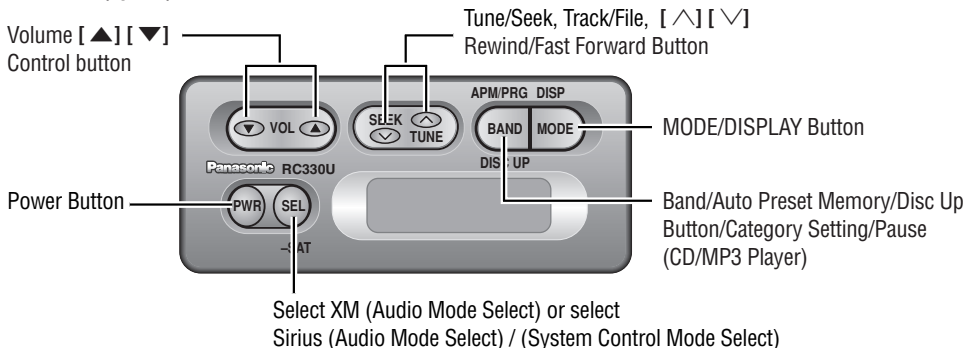

Note:

CD changer functions are applicable to units with optional CD changer unit.
(sold separately)

**Scan Play
(Tracks)**

- Press **[4] (SCAN)**. The track number blinks and the first 10 seconds of each track on the discs play in sequence.
- Press **[4] (SCAN)** again to cancel and continue with the current track.

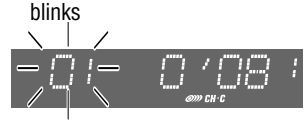

**Scan Play
(Discs)**

- Press and hold **[4] (SCAN)** for more than 2 seconds. The first track of the next discs in the magazine is played for 10 seconds each and Disc Number blinks.
- Press and hold **[4] (SCAN)** for more than 2 seconds again to cancel.



**Repeat Play
(Track)**

- Press **[5] (REPEAT)** to repeat the current track.
- Press **[5] (REPEAT)** again to cancel.



**Repeat Play
(Disc)**

- Press and hold **[5] (REPEAT)** for more than 2 seconds to repeat the current disc.
- Press and hold **[5] (REPEAT)** for more than 2 seconds again to cancel.



**Random Play
(Tracks)**

- Press **[6] (RANDOM)** to random selection. Music is played from all available CDs.
- Press **[6] (RANDOM)** again to cancel.



**Random Play
(Discs)**

- Press and hold **[6] (RANDOM)** for more than 2 seconds all the available tracks on the current disc play in a random sequence.
- Press and hold **[6] (RANDOM)** for more than 2 seconds again to cancel



**Random
Repeat Play
(Tracks)**

- Press **[6] (RANDOM)** to random selection and then press **[5] (REPEAT)**. Music is played from all available CDs and then repeated the current tracks.
- Press **[6] (RANDOM)** again to cancel.



**Random
Repeat Play
(Disc)**

- Press and hold **[6] (RANDOM)** for more than 2 seconds all the available tracks on the current disc play in a random sequence and then repeated the current tracks.
- Press and hold **[6] (RANDOM)** for more than 2 seconds again to cancel.



XM Control

Getting Started

It is required to sign up to become an XM Satellite Radio subscriber. After checking your XM Satellite Radio ID, sign up on the XM's website or by calling them.

① Check of XM Satellite Radio ID

- Write down the ID indicated on the lower right of your XM receiver (XM-RVR-FM-001, option).

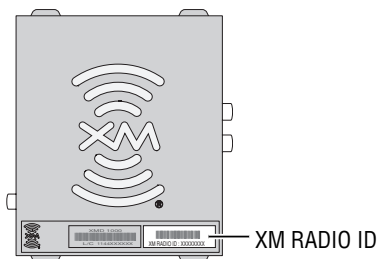

- Check the ID shown by tuning your XM Radio to channel 0.
(Refer to "XM ID Confirmation" on page 25).

RADIO ID display (Example)



② Activate the XM Satellite Radio

Select either of the below to sign up

- Web site: <http://www.xmradio.com/activation>
- Phone number: 1-800-852-9696

Preparation:

Connect the XM receiver (XM DIRECT MODEL:XM-RVR-FM-001) to the Unit CQ-5302U.
XM satellite radio is available on a chargeable basis.

② Band

Press [BAND].

XM1 → XM2 → XM3

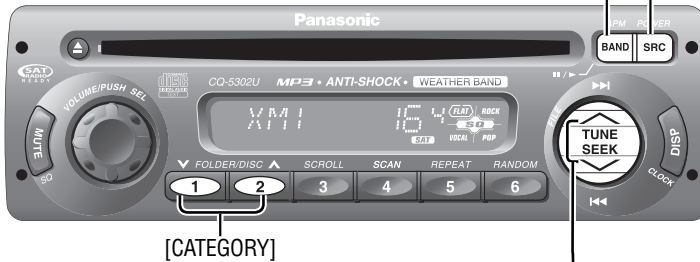

① XM Mode

(When a XM receiver is connected.)
Press [SRC] to change to the XM mode.

③ Channel Selection

- Manual Tuning
Press [▲TUNE]: Up
Press [▼TUNE]: Down
- Seek Tuning
Press and hold for more than 0.5 seconds and release it.
[▲SEEK]: Up
[▼SEEK]: Down
Tuning will automatically stop when the next broadcast station is received.

Note: Tuning will change into the ID confirmation display when selecting channel 0.

XM displays as follows, (Example)

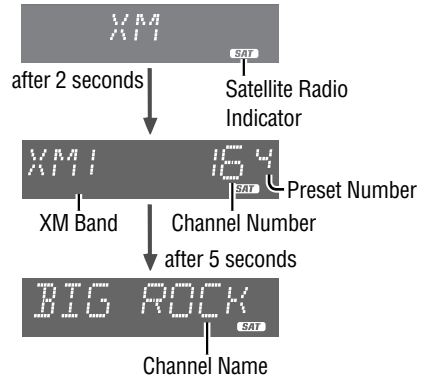

Category Priority Setting and Selecting

*You can toggle the category on and off every time you hold down [BAND] for 2 seconds.

XM1 164
SAT

↓ (press [BAND] for more than 2 seconds to set category ON.)

CAT ON
SAT

↓ (after 2 seconds)

XM1c 164
SAT

XM1c 164
SAT

(when category is set ON.)

↓ (press [BAND] for more than 2 seconds to set category OFF.)

CAT OFF
SAT

↓ (after 2 seconds)

XM1 164
SAT

XM Control (Continued)

- When the display shows "CATEGORY",
Press [2] (▲): Up
Press [1] (▼): Down

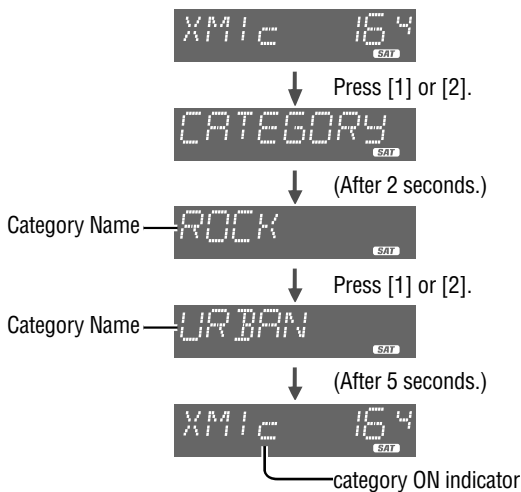
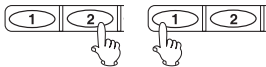

Notes:

- CAT OFF: Every channel can be selected from every category.
- CAT ON: Only channels in the current category can be selected.
- Default: CAT OFF

Manual Preset Memory

Up to 6 channels each can be saved in the XM1, XM2 and XM3 preset station memories.

- Select a band and a channel.

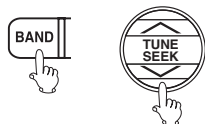

- Press and hold [1] to [6] for more than 2 seconds to memorize.

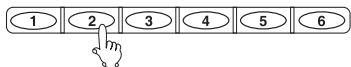

- The channel number and the preset number blink once.

Note:

Existing saved channels are overwritten with new channels after the above procedure.

Preset memory Calling

- Select a band.
- Press [1] to [6].

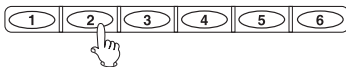

Note:

When category is on category will be off after pressed any preset button [1] to [6].

Display Change

Press **[DISP]** to change the display.



Note:

- “ADJUST” is displayed when the clock is not adjusted.
-  Display when there is no name/title or can not decode.

XM ID Confirmation

• Press **[^]** or **[v]** to select channel 0 then start XM ID confirmation.

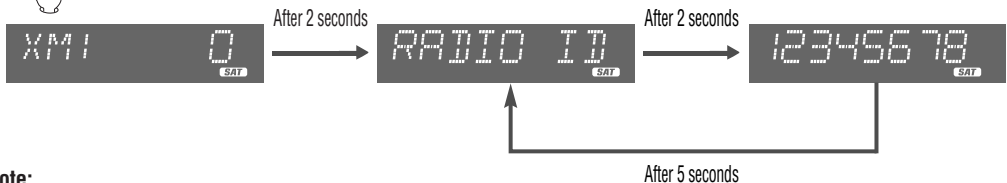

Note:

If the ID number is 12345678 for example.
(8-digit ID number always appears.)

Error display



XM communication fails, Press **[SRC]** to another mode.

Sirius Control

What is Sirius Satellite Radio?

Over 120 channels of the best entertainment and completely commercial-free music for your car, home or office.

Only SIRIUS has more than 65 original music channels, from today's hits to R&B oldies to classical master-pieces. From authentic country and real Bluegrass to cool Jazz, hot Latin, Reggae, Rock and many more. Best of all, it's all completely commercial-free.

SIRIUS also has more than 55 channels of world-class sports, news and entertainment. Included as part of your subscription, you get up to 16 NFL games a week, up to 40 NBA games a week and up to 40 NHL games a week. (Games are broadcasted during their respective seasons.) Coupled with great sports news from ESPN, the SIRIUS sports offering is unrivaled. And don't forget a host of other great news and entertainment, like NPR, CNBC, Fox News, Radio Disney and E!Entertainment Radio.

With SIRIUS, the emphasis is on the music and entertainment you want. The music is hosted by SIRIUS Jockeys, who are true experts. They back-up the music with compelling information about the song being played, and they understand that sometimes it's best to just let the music speak for itself.

Rely on SIRIUS rocket science for superior coverage.

Only SIRIUS has three powerful satellites that fly directly over the U.S. ensuring coast-to-coast coverage with high elevation angles. This gives the satellites a "clear line of sight" to your car or home, with much less concern for buildings, trees or other objects that might block conventional satellite signals.

once you experience more than 120 channels of digital entertainment, you'll never want to leave your car. For more information, visit www.sirius.com.

Connecting Sirius receiver

- Connect the optional Sirius receiver (SIR-PAN 1).

Note:

It is required to sign up to become a Sirius Satellite Radio Subscriber. After checking your Sirius Satellite Radio ID, sign up on the Sirius's website or by calling them.

Getting Started

① Check of Sirius Satellite Radio ID

- Check the ID shown by tuning your Sirius Satellite Radio to channel 0.
(Refer to "SR ID Confirmation" on page 29).

RADIO ID display (Example)



Note:

You can also check the ID shown by selecting system control mode. (Refer to RADIO ID on page 31)

② Activate the Sirius Satellite Radio

Select either of the below to sign up

- Web site: <http://home.sirius.com/webCUWI>
- Phone number: 1-888-539-SIRIUS(7474)

Sirius Satellite broadcast service

The Sirius Satellite coverage is only for the United States except Hawaii and Alaska. There is no Sirius Satellite coverage in Canada. The instruction of Satellite Operation controls in the Operating Instructions and Guide will not be applied.

② Band

Press [BAND].

SRI → SR2 → SR3

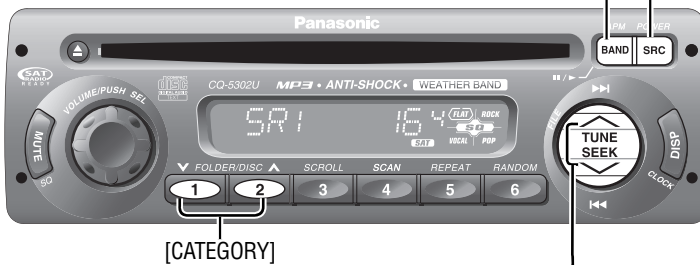

① Sirius Mode

(When a Sirius receiver is connected and Sirius setting is SET ON.)

Press [SRC] (source) to change to the Sirius mode.

③ Channel Selection

- Manual Tuning
Press [▲TUNE]: Up
Press [▼TUNE]: Down
- Seek Tuning
Press and hold for more than 0.5 seconds and release it.
[▲SEEK]: Up
[▼SEEK]: Down
Tuning will automatically stop when the next broadcast station is received.

Note:

Tuning will change into the ID confirmation display when selecting channel 0.

Sirius control mode display (Example)

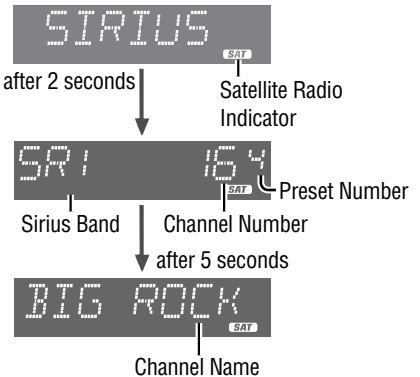

Category Priority Setting and Selecting

You can toggle the category on and off every time you hold down [BAND] for 2 seconds.

SRI 164

↓ (press [BAND] for more than 2 seconds to set category ON.)

CAT ON

↓ (after 2 seconds)

SRI 164

SRI 164

(when category is set ON.)

↓ (press [BAND] for more than 2 seconds to set category OFF.)

CAT OFF

(when category is set OFF.)

↓ (after 2 seconds)

SRI 164

Sirius Control (Continued)

- When the display shows "CATEGORY",
Press [2] (▲): Up
Press [1] (▼): Down

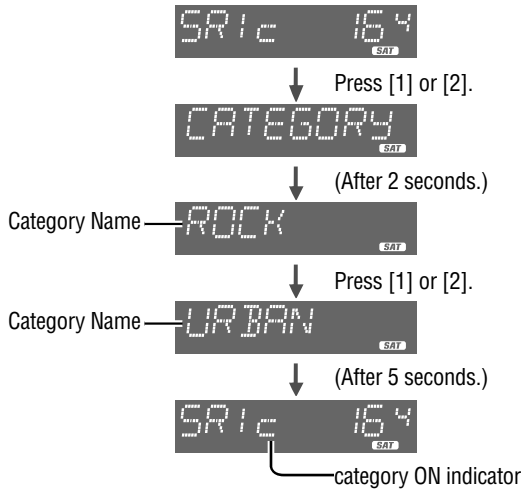
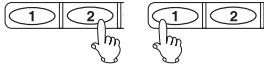

Notes:

- CAT OFF: Every channel can be selected from every category.
- CAT ON: Only channels in the current category can be selected.
- Default: CAT OFF

Manual Preset Memory

Up to 6 channels each can be saved in the SR1, SR2 and SR3 preset station memories.

- Select a band and a channel.



- Press and hold [1] to [6] for more than 2 seconds to memorize.

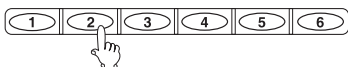

- The channel number and the preset number blink once.

Note:

Existing saved channels are overwritten with new channels after the above procedure.

Preset memory Calling

- Select a band.
- Press [1] to [6].

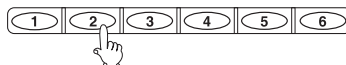

Note:

When category is on category will be off after pressed any preset button [1] to [6].

Display Change

Press **[DISP]** to change the display.

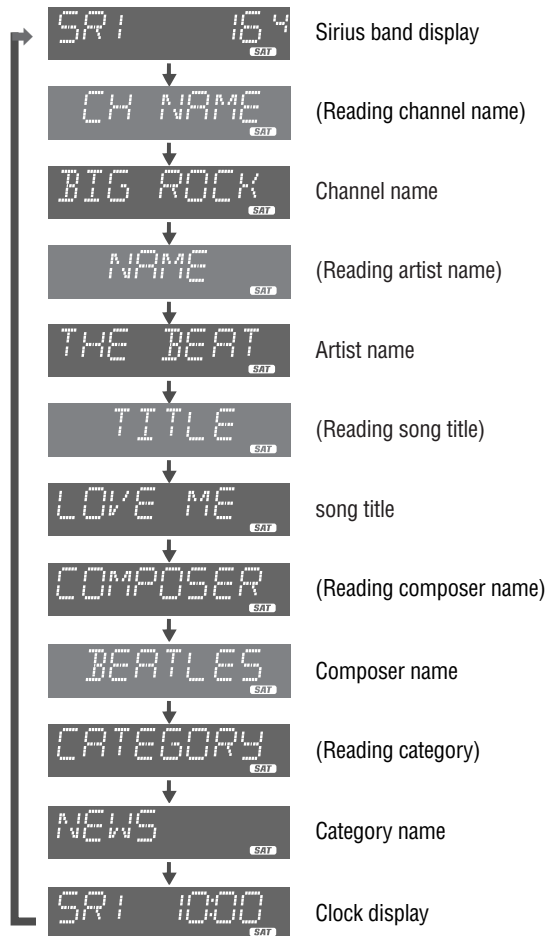

Note:

- “ADJUST” is displayed when the clock is not adjusted.
-  Display when there is no name/title or can not decode.

SR ID Confirmation

• Press TUNE **[^]** or **[v]** to select channel 0 then start Sirius ID confirmation.

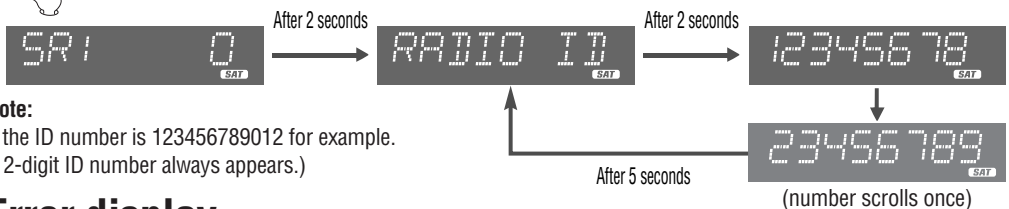

Note:

If the ID number is 123456789012 for example. (12-digit ID number always appears.)

Error display



SR communication fails, Press **[SRC]** to another mode.

Sirius Control (Continued)

System Control Mode

- Press the knob [SEL] for more than 2 seconds to select the system control mode as follows:



□ Parental Channel Lock/Unlock Setting

This function allows users to lock unfavorable channels and to release locking.

- ① Push the knob [SEL] for more than 2 seconds.

P-LOCKCH

↓ (after 2 seconds)

- ② Press button [1] to [6] to enter the 4-digit pass code number. (Default: 1111)

CODE

↓ (press [BAND] to confirm the pass code)

- ③ Press TUNE \wedge / TUNE \vee to select a channel to be locked or unlocked.

CH

↓

- ④ Press button [2] \wedge / [1] \vee to Lock/Unlock the channel.

• Press button [2] \wedge

• Press button [1] \vee

LOCK SET (Channel lock activation)

UNLOCK (Channel lock cancellation)*

↓ (after 2 seconds)

↓ (after 2 seconds)

CH

(select the next channel)

- ⑤ Press [BAND] to confirm the channel and return to the Sirius band display mode.

SRI 16 SAT

Sirius band display

Note:

- The input pass code number will be converted into an asterisk (**) when you enter the pass code.
- To suspend lock/unlock setting, press [DISP].
- * Refer to the next page for another way to unlock the channel, in addition.

☐ To unlock the channel by tuning into the station.

You can also unlock the channel via tuning into the station.

- Press **TUNE** \wedge / **TUNE** \vee to select a channel that is already locked.

SRI 185 SAT

(Sirius band display)



LOCK- 185

(the channel has been locked)



after 2 seconds

CODE _ _ _ _

(pass code input mode)



(press button **[1]** to **[6]** to enter the 4 - digit pass code number. (Default: 1111)
Then press **[BAND]** to confirm the pass code.

UNLOCK

(Channel lock cancellation)



after 2 seconds

SRI 185 SAT

(Sirius band display)

- **Error display**

INVALID

After 2 seconds

CODE _ _ _ _

enter the pass code again.

The pass code is incorrect.

☐ RADIO ID

SR ID Confirmation

RADIO ID SAT

After 2 seconds

12345678 SAT

After 2 seconds

(number scrolls once)

23456789 SAT



After 5 seconds

Note:

If the ID number is 123456789012 for example. (12-digit ID number always appears.)

- Press **[DISP]** to resume to the previous mode when displaying “RADIO ID” or ID number.
- You can also see ID number by selecting channel 0.

Sirius Control (Continued)

Pass Code Change/Setting

The pass code is changeable (default: 1111)

- How to change your pass code:

- ① Push the knob [SEL] for more than 2 seconds.



P-LOCKCH

↓ (after 2 seconds)

- ② Press button [1] to [6] to enter the preset (old) 4-digit pass code number.
(Default: 1111)

- If the wrong pass code is entered, a new pass code cannot be registered.



CODE

↓ (press [BAND] to confirm the pass code)



CH

↓ (press [BAND] for more than 2 seconds)



NEW CODE

↓ (after 2 seconds)

- ③ Press button [1] to [6] to enter a new 4-digit pass code number.



CODE

↓ (Press [BAND] to confirm the new pass code)

- ④ Enter the new 4-digit pass code number again.



CODE

↓ (Press [BAND] again to make final confirmation)



CODE SET

new pass code setting completed

↓ (after 2 seconds)



SR1 16

Sirius band display

Error display

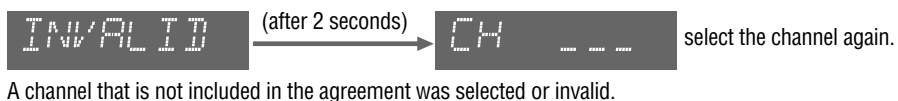

Note:

- To suspend pass code setting, press **[DISP]**.

Troubleshooting

❑ If You Suspect Something Wrong

Check and take steps as described below.

If the described suggestions do not solve the problem, it is recommended to take the unit to your nearest authorized Panasonic Servicenter. The product should be serviced only by qualified personnel. Please refer the checking and the repair to professionals. Panasonic shall not be liable for any accidents arising out of neglect of checking the unit or your own repair after your checking.

Warning

- Do not use the unit in an irregular condition, for example, without sound, or with smoke or a foul smell, which can cause ignition or electric shock. Immediately stop using the unit and consult your dealer.
- Never try to repair the unit by yourself because it is dangerous to do so.

Troubleshooting Tips

❑ Common

Problem	Possible cause → Possible solution
No power.	Vehicle's ignition switch is not on. → Turn your vehicle's ignition switch to ACC or ON.
	Cables are not correctly connected. → Connect cables correctly.
	Power connector is not correctly connected. → Connect the power connector to the terminal that is always active.
	Power connector is not correctly connected. → Connect the power connector to your vehicle's ACC source.
	Grounding wire is not correctly connected. → Connect the grounding wire to a metal part of the vehicle.
No sound.	Mute is set to ON. → Set it to OFF.
	Cables are not correctly connected. → Connect cables correctly.
Noise.	The ground lead is not connected properly. → Connect the ground lead properly.

☐ Radio

Problem	Possible cause → Possible solution
Much noise in FM stereo and monaural broadcasts.	Station is too far, or signals are too weak. → Select other stations of higher signal level.
Preset station is reset.	The radio antenna is not extended enough. → Extend fully the radio antenna.
	Battery cable is not correctly connected. → Connect the battery cable to the terminal that is always active.

☐ CD

Problem	Possible cause → Possible solution
Disc is in the CD compartment but no sound is made, or disc is ejected automatically.	Disc is upside down. → Place disc in the correct direction with the label side up.
	<ul style="list-style-type: none">• Disc is dirty.• Disc has scratches. → Clean disc, referring to the section on “Notes on Discs”.
	A disc that has data other than CD-DA type is loaded. → Discs that have CD-DA type data should be used.
	→ The unit may not successfully playback a CD-R/RW that is made in combination of writing software, a CD recorder (CD-R/RW drive) and a disc which are incompatible one another. Refer to instructions for the concerned devices for details.
Sound skips, bad sound quality. (e.g. caused by noise)	<ul style="list-style-type: none">• Disc is dirty.• Disc has scratches. → Clean disc, referring to the section on “Notes on Discs”.
	→ The unit may not successfully playback a CD-R/RW that is made in combination of writing software, a CD recorder (CD-R/RW drive) and a disc which are incompatible one another. Refer to instructions for the concerned devices for details.
Sound skips due to vibration.	Mounting angle is over 30°. → Adjust mounting angle to less than 30°.
	Instable mounting. → Mount the unit securely with the mounting parts, referring to the section on installation.
Disc is not ejected.	<ul style="list-style-type: none">• Disc is defective.• Mechanical trouble. → Press [▲] (eject). If normal operation is not restored, call the store where you purchased the unit or the nearest Servicerenter to ask for repairs.
Time is counted but no sound comes out.	The first track of a mix mode disc was reproduced. (Mix mode is a format in which data except music is recorded on the first track and music data is recorded on other than the first track in a session.) → Playback music data recorded on other than the first track.

Troubleshooting (Continued)

MP3

Problem	Possible cause → Possible solution
No playback or disc ejected	The disc has unplayable formatted data. → Refer to the description about MP3 for playable sound data except CD-DA (i.e. music CD)
The CD-R/RWs that are playable on other devices are not playable on this unit.	The playability of some CD-R/RWs may depend on the combination of media, recording software and recorder to be used even if these CD-R/RWs are playable on other devices such as a PC. → Make CD-R/RWs in different combination of media, recording software and recorder after referring to the description about MP3.
Sound skipping or noise	There is a flaw or foreign material on the disc. → Remove the foreign material, or use a flawless disc. For MP3, refer to the description about MP3.
	Playing VBR (Variable Bit Rate) files may cause sound skipping. → Play Non-VBR files.

Sound Setting

Problem	Possible cause → Possible solution
No sound from left, right, front, or rear speaker.	Left and right balance, or front and rear balance is off on one side. → Adjust BAL/FAD as appropriate.
Left and right sounds are reversed in stereo listening.	Cables are not correctly connected. → Connect the cables correctly.
	The right speaker wire is connected to the left speaker and the left speaker wire to the right speaker. → Connect the speaker wires to the correct ones.

XM Receiver

Problem	Possible cause → Possible solution
ANTENNA	Antenna no connection. → Check the XM receiver's antenna.
NO SINGL	No XM signal. → select a channel which can be received.
OFF AIR	No channel service. → select a channel which can be received.
NO XM	Do not connect the XM receiver completely. → Check the XM receiver's connections.





☐ Sirius Satellite Radio

Problem	Possible cause → Possible solution
NO SR	Cannot receive Sirius Satellite Radio. → Verify the wiring.
ANTENNA ERROR	Sirius antenna unconnected. → Connect the Sirius antenna.
CALL 888-539-SIRIUS	User's registration has not been carried out. → Complete user's registration.
	A channel that is not included in the agreement was selected. → Select a channel that is included in the agreement. Refer to the operating instructions for Sirius receiver with regard to the agreement.
SUBSCRIPTIONUPDATED	The subscription information was updated. → Wait for 3 minutes in the Sirius mode.
AQUIRING SIGNAL	Your location is out of receivable areas (e.g. in a tunnel), or the unit is decoding a selected broadcast. The display appears also while the connections are being checked after the power has been turned on. → Wait until getting out of the unreceivable area or completing the decoding.
INVALID CHANNEL	The selected channel is invalid. → Select a channel which can be received instead.
UPDATING CHANNEL	The channel data is uploading. → Please waiting for the response.
SR-E-H	Hardware error messages. → Check the Hardware carefully.





Troubleshooting (Continued)

Error Display Messages

❑ CD/MP3

Display	Possible cause → Possible solution
	Disc is dirty, or is upside down. A disc that has data other than CD-DA type is loaded. → Check the disc.
	Disc has scratches. → Check the disc.
	No operation by some cause. → If normal operation is not restored, call the store where you purchased the unit or the nearest Servicenter to ask for repairs.
	The player for some reason cannot read the file you are trying to play. (file recorded in an unsupported file system. compression scheme, data format, file name extension, damaged data, etc.) → Select a file that the player can read. Check the type of data recorded on the disc. Create a new disc if necessary.

❑ CD changer

	Disc is dirty, or is upside down. → Select the next available compact disc. Check the disc.
	Disc has scratches. → Select the next available compact disc. Check the disc.
	No operation by some cause. → Eject the magazine. If failure persists, press the reset switch on the CD changer. If normal operation is not restored yet, call the store where you purchased the unit to the nearest panasonic Servicenter to ask for repairs.
	No disc in the changer (magazine) → Insert discs into the changer (magazine).

Maintenance

Care of the Unit

☐ Cleaning this Unit

Use a dry, soft cloth to wipe.

☐ Caution on Cleaning

Never use solvents such as benzene, thinner as they may mar the surface of the unit.

Notes on Discs

If you use commercial CDs, they must have either of these labels shown at right.
Some copy-protected music CDs are not playable.



How to hold a disc

- Do not touch the underside of a disc.
- Do not scratch on a disc.
- Do not bend a disc.
- When not in use, keep a disc in a case.

Do not use irregularly shaped discs.

Do not leave discs in the following places:

- Direct sunlight
- Near car heaters
- Dirty, dusty and damp areas
- Seats and dashboards

Disc cleaning

Use a dry, soft cloth to wipe from the center outward.

Do not attach any seals or labels to your discs.

Do not write on the disc label with a ballpoint pen or other hard-point pens.

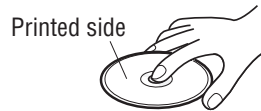

Do not attach any seals or labels to your discs.



Do not use irregularly shaped discs.



<Correct>



<Wrong>

Maintenance (Continued)

Notes on CD-Rs/RWs

- You may have trouble playing back some CD-R/RW discs recorded using CD recorders (CD-R/RW drives), either due to their recording characteristics or dirt, fingerprints, scratches, etc. on the disc surface.
- CD-R/RW discs are less resistant to high temperatures and high humidity than ordinary music CDs. Leaving them inside a car for extended periods may damage and make playback impossible.
- Some CD-R/RWs cannot be played back successfully due to incompatibility among writing software, a CD recorder (CD-R/RW drive) and the discs.
- This player cannot play the CD-R/RW discs if the session is not closed.
- This player cannot play the CD-R/RW discs which contain other than CD-DA data or MP3.
- Be sure to observe the instructions of the CD-R/RW disc for handling it.
- The file extension “.mp3” should be assigned to each file depending on the file format.
- This unit does not have the play list function.
- Although Multi-session recording is supported, the use of Disc-at-Once is recommended.

Supported file systems

ISO 9660 Level 1/Level 2, Apple Extension to ISO 9660, Joliet, Romeo

Note: Apple HFS, UDF 1.50, MIX mode CD, CD Extra is not supported.

Compression formats

(Recommendation: “Points to remember when making MP3 files” on the next page.)

Recording MP3 files on a CD-media

- **You are recommended to minimize the chances of making a disc that contains both CD-DA files and MP3 files.**
- **If CD-DA files are on the same disc as MP3 or files, the songs may not play in the intended order, or some songs may not play at all.**
- Do not record files other than MP3 files and unnecessary folder on a disc.
- The name of MP3 file should be added by rules as shown in the following descriptions and also comply with the rules of each file system.
- You may encounter trouble in playing MP3 files or displaying the information of MP3 files recorded with certain writing software or CD recorders.
- **MPEG 1 audio layer 3**
Bit rate: 32 k-320 kbps
VBR: Yes
Sampling frequency:
32, 44.1, 48 kHz
- **MPEG 2 audio layer 3**
Bit rate: 8 k-160 kbps
VBR: Yes
Sampling frequency:
16, 22.05, 24 kHz

Notes on MP3

Note: MP3 encoding and writing software is not supplied with this unit.

Points to remember when making MP3 files

- High bit rate and high sampling frequency are recommended for high quality sounds.
- Selecting VBR (Variable Bit Rate) is not recommended because playing time is not displayed properly and sound may be skipped.
- The playback sound quality differs depending on the encoding circumstances. For details, refer to the user manual of your own encoding software and writing software.
- It is recommended to set the bit rate to “128 kbps or more” and “fixed”.

Caution

Never assign the “.mp3”, file name extension to a file that is not in the MP3 format. This may not only produce noise from the speaker damage, but also damage your hearing.

Display Information

Displayed items

- | | |
|---|--|
| • CD-TEXT
Disc title
Track title | • MP3 (ID3 tag)
Album name
Title name/Artist name |
| • MP3
Folder name
File name | |

Displayable characters

- Name files and folders in accordance with the standard of each file system. Refer to the instructions of writing software for details.
- ASCII character set and special characters in each language can be displayed.

Notes:

- With some software in which MP3 format files have been encoded, the character information may not be displayed properly.
- Undisplayable characters and symbols will be converted into an asterisk (*).

Folder selection order/file playback order

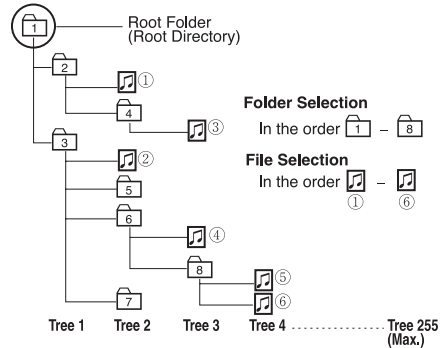

Maximum number of files/folders

- Maximum number of files: 999
- Maximum number of files in one folder: 255
- Maximum depth of trees: 255
- Maximum number of folders: 255 (Root folder is included.)

Notes:

- This unit counts the number of folders irrespective of the presence or absence of MP3 file.
- If the selected folder does not contain any MP3 files, the nearest MP3 files in the order of playback will be played.
- Playback order may be different from other MP3 players even if the same disc is used.
- “ROOT” appears when displaying the root folder name.

Copyright

It is prohibited by copyright laws to copy, distribute and deliver copyrighted materials such as music without the approval of copyright holder except enjoying yourself personally.

No warranty

Above description complies with our investigations as of December 2005. It has no warranty for reproducibility and displayability of MP3.

Speaker Connections

⚠ Caution: Please follow the instructions given below. Failure to do so will cause damage to the unit and speakers.

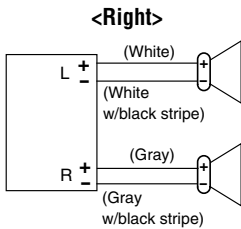

- Use ungrounded speaker only.
- The maximum speaker input should be 37 W or more. (If used with the optional power amplifier, the speaker input should be higher than the maximum amplifier output.)
- The speaker impedance should be 4 - 8 Ω .
- This unit uses the BTCL circuit, so each speaker should be connected separately using parallel vinyl insulated cords.
- The speaker cords and the power amplifier unit should be kept away (about 30 cm apart) from the antenna and antenna extension cord.

<Wrong>

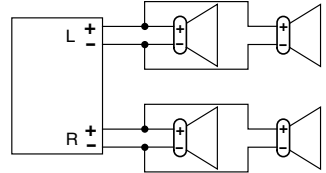
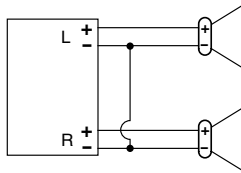
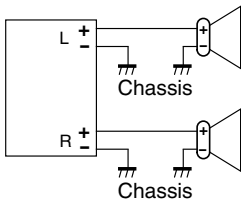

- Never connect the speaker cord to the body of the car.
- Do not use a 3-wire type speaker system having a common earth lead.
- Do not connect more than one speaker to one set of speaker leads.

Product Servicing

If the suggestions in the charts do not solve the problem, we recommend that you take it to your nearest authorized Panasonic Service center. The product should be serviced only by a qualified technician.

Maintenance

Your product is designed and manufactured to ensure the minimum of maintenance. Use a soft cloth for routine exterior cleaning. Never use benzine, thinner, or other solvents.

Caution

This product is designed without a fuse inside due to fuses already exist in your vehicle. We would recommend to use fuses of the specified rating (10 A). Using fuses that exceed the prescribed capacity could cause this product to start smoking, ignite or other malfunction.

If your vehicle is without the fuse or a circuit breaker to protect this unit, please your dealer add the specified fuse 10 A or a circuit breaker at the BATTERY lead of your vehicle's harness. please see page 47 to find out where "BATTERY + 12 V" is for your dealer adding the fuse or the circuit breaker.

Installation Guide



WARNING

❑ This installation information is designed for experienced installers and is not intended for non-technical individuals. It does not contain warnings or cautions of potential dangers involved in attempting to install this product.

Any attempt to install this product in a vehicle by anyone other than a qualified installer could cause damage to the electrical system and could result in serious personal injury or death.

❑ If your vehicle is equipped with air bag and/or anti-theft systems, specific procedures may be required for connection and disconnection of the battery to install this product.

Before attempting installation of this electronic component, contact your vehicle dealer or manufacturer to determine the required procedure and strictly follow their instructions.

FAILURE TO FOLLOW THE PROCEDURE MAY RESULT IN THE UNINTENDED DEPLOYMENT OF AIR BAGS OR ACTIVATION OF THE ANTI-THEFT SYSTEM RESULTING IN DAMAGE TO THE VEHICLE AND PERSONAL INJURY.

❑ Overview

This product should be installed by a professional. However, if you plan to install this product yourself, your first step is to decide where to install it. The instructions in these pages will guide you through the remaining steps:

(Please refer to the "WARNING" statement above.)

- Identify and label the car wires.
- Connect the vehicle wires to the wires of the power connector.
- Install the unit in the dashboard.
- Check the operation of the unit.

If you encounter problems, please consult your nearest professional installer.

⚠ Caution

This unit operates with a 12 V DC negative ground auto battery system only. Do not attempt to use it in any other system. Doing so could cause serious damage.

Before you begin installation, look for the item which is packed with your unit.

- **Installation Hardware**...Needed for in-dash installation.

❑ Dashboard Specifications

Thickness Min. 4.75 mm {3/16"}
Max. 5.56 mm {7/32"}

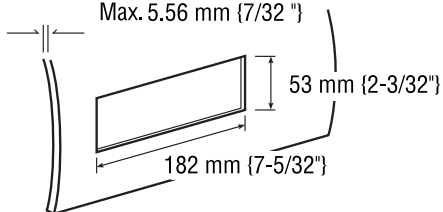

Installation

□ Preparation

⚠ Warning

If your vehicle is equipped with air bag and/or anti-theft systems, specific procedures may be required for connection and disconnection of the battery to install this product.

Before attempting installation of this electronic component, contact your vehicle dealer or manufacturer to determine the required procedure and strictly follow their instructions.

FAILURE TO FOLLOW THE PROCEDURE MAY RESULT IN THE UNINTENDED DEPLOYMENT OF AIR BAGS OR ACTIVATION OF THE ANTI-THEFT SYSTEM RESULTING IN DAMAGE TO THE VEHICLE AND PERSONAL INJURY.

- Disconnect the cable from the negative ⊖ battery terminal (see warning and caution below).
- Remove Mounting Collar ① from the main unit temporarily, which are already mounted at shipment. *

⚠ Caution

Various settings that have been stored in the memory in other on-board equipment (vehicle navigation etc.) may be lost if the battery terminals are disconnected.

Therefore, we recommend to make a record of or to back up the settings before disconnecting the terminals.

After completing installation of the main unit, set the equipment again according to the record.

- Unit should be installed in a horizontal position with the front end up at a convenient angle, but not more than 30°.

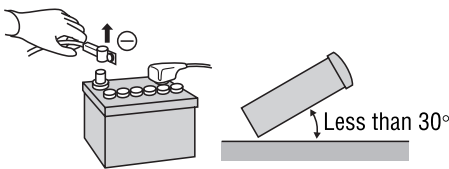

□ Dashboard Installation

Installation Opening

This unit can be installed in any dashboard having an opening as shown below. The dashboard should be 4.75mm {3/16"} – 5.56 mm {7/32"} thick in order to be able to support the unit.

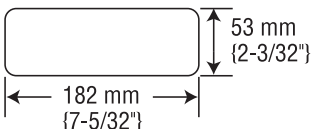

□ Installation Hardware

No.	Item	Diagram	Q'ty
①	Mounting Collar*		1
②	Plain washer (5mmø)		2
③	Spring Washer (5mmø)		2
④	Hex. Nut (5mmø)		2
⑤	Rear Support Strap		1
⑥	Hex. Bolt (5mmø × 25 mm)		1
⑦	Toothed Lock Washer (5mmø)		1
⑧	Removal Tool (U-shaped)		2
⑨	Antenna Connector		1

(a) Using the rear support strap ⑤

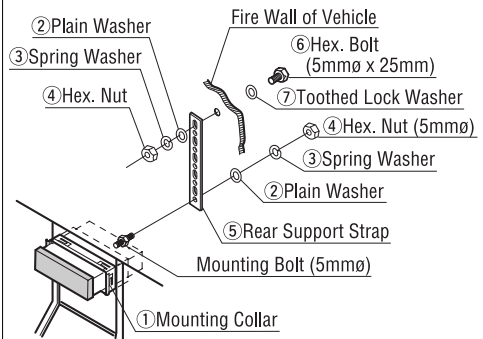

(b) Using the rubber cushion (option)

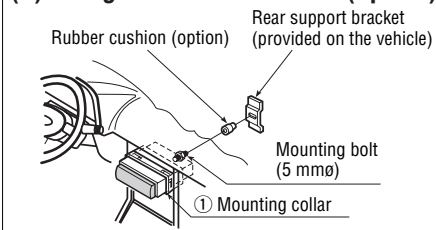

Caution

- We strongly recommend that you wear gloves for installation work to protect yourself from injuries.
- When bending the mounting tab of the mounting collar with a screwdriver, be careful not to injure your hands and fingers.

First complete the electrical connections, and then check them for correctness. (→ page 47)

The included Mounting Collar ① is designed specially for this unit. Do not use it to attach any other model.

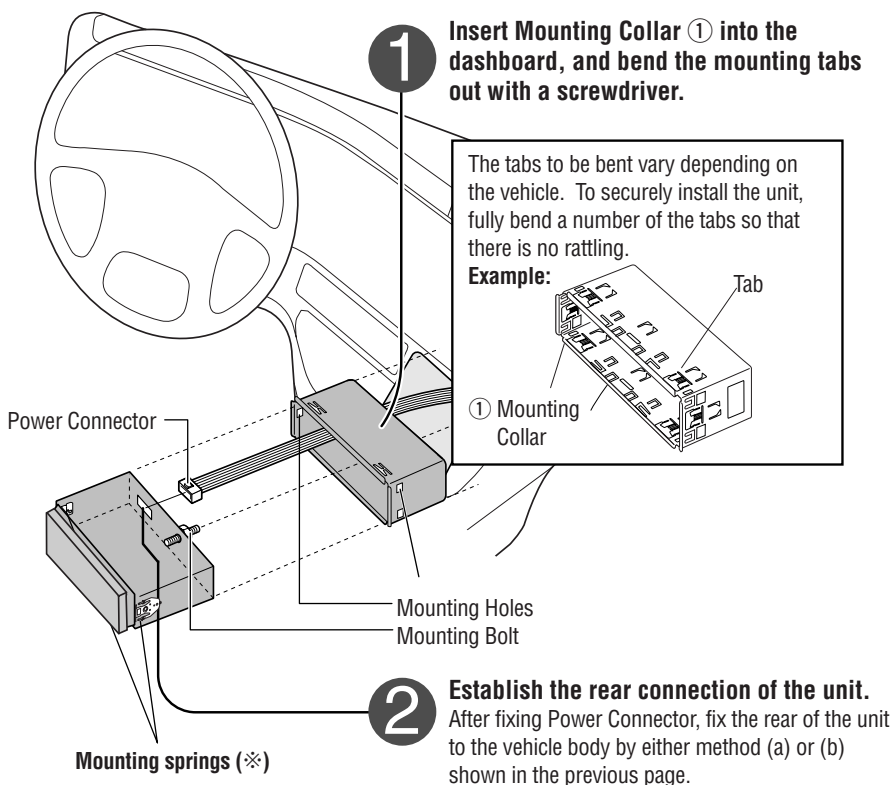

Engage the Mounting Springs (※) in the mounting holes of the Mounting Collar ① firmly.

Mounting Spring

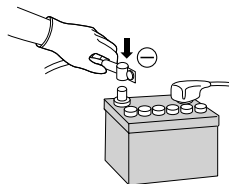
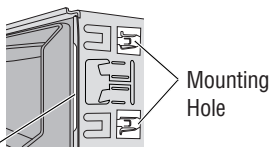

Installation (Continued)

To Remove the Unit from the vehicle's dashboard

Insert each Removal Tool ⑧ and pull.

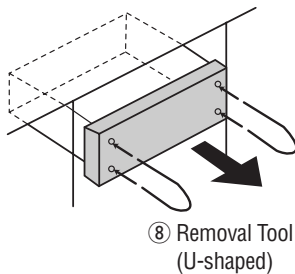

Note: Do not lose Removal Tools. They will be needed to remove the unit from the vehicle's dashboard.

Electrical Connections

⚠ Caution

- This wiring information is for experienced technical individual, for safety reason, please your dealer wire this connection.
- This product is designed to operate with a 12 V DC, negative ground battery system.
- To prevent damage to the unit, be sure to follow the connection diagram below.
- Do not insert the power connector into the unit until the wiring is completed.
- Be sure to insulate any exposed wires from a possible short-circuit from the vehicle chassis. Bundle all cables and keep cable terminals free from touching any metal parts.
- Remember, if your vehicle has a drive computer or a navigation computer, the data of its memory maybe erased when the battery terminals are disconnected.

□ Wiring Diagram

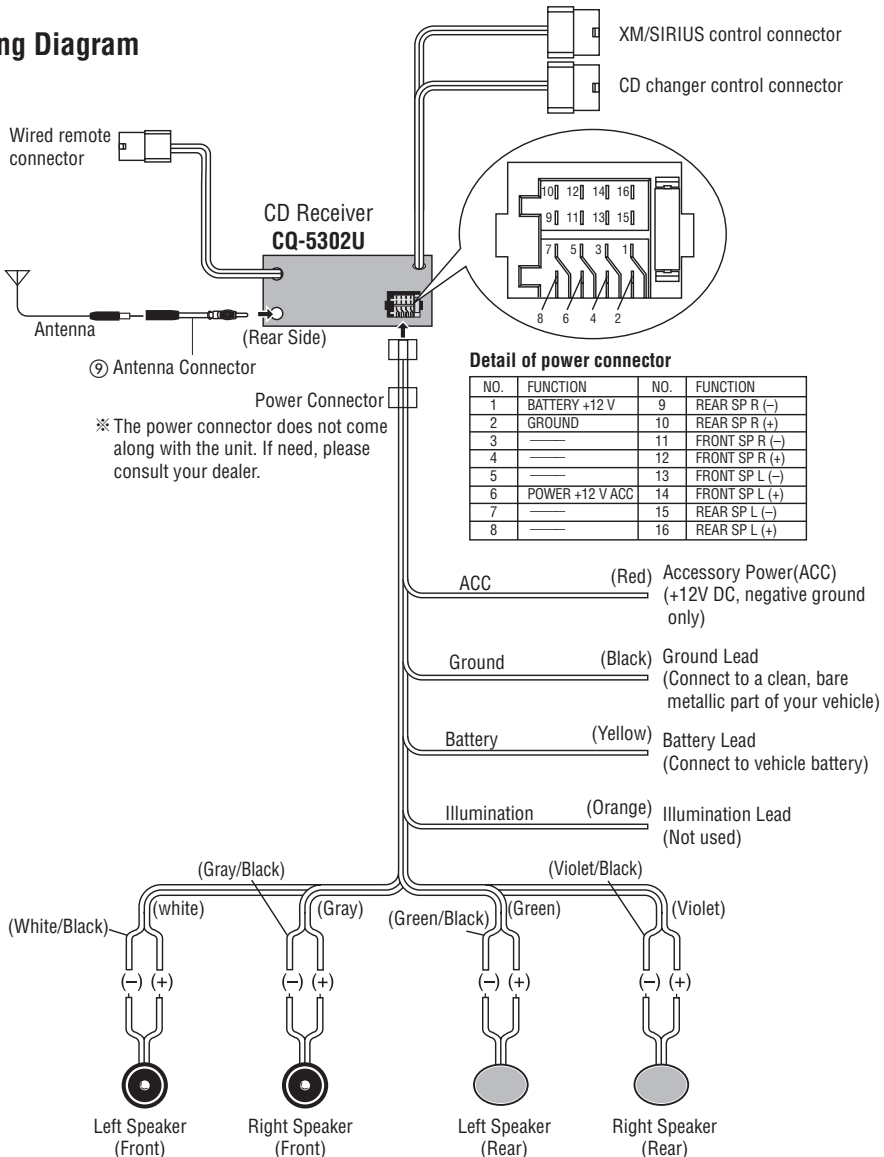

Electrical Connections (Continued)

□ Upgrading the system (connect a Sirius receiver and the wired remote.)

Example combination

- Sirius receiver (SIR-PAN1, option)

Note:

- For wiring, carefully read the operating instructions for the devices connected.

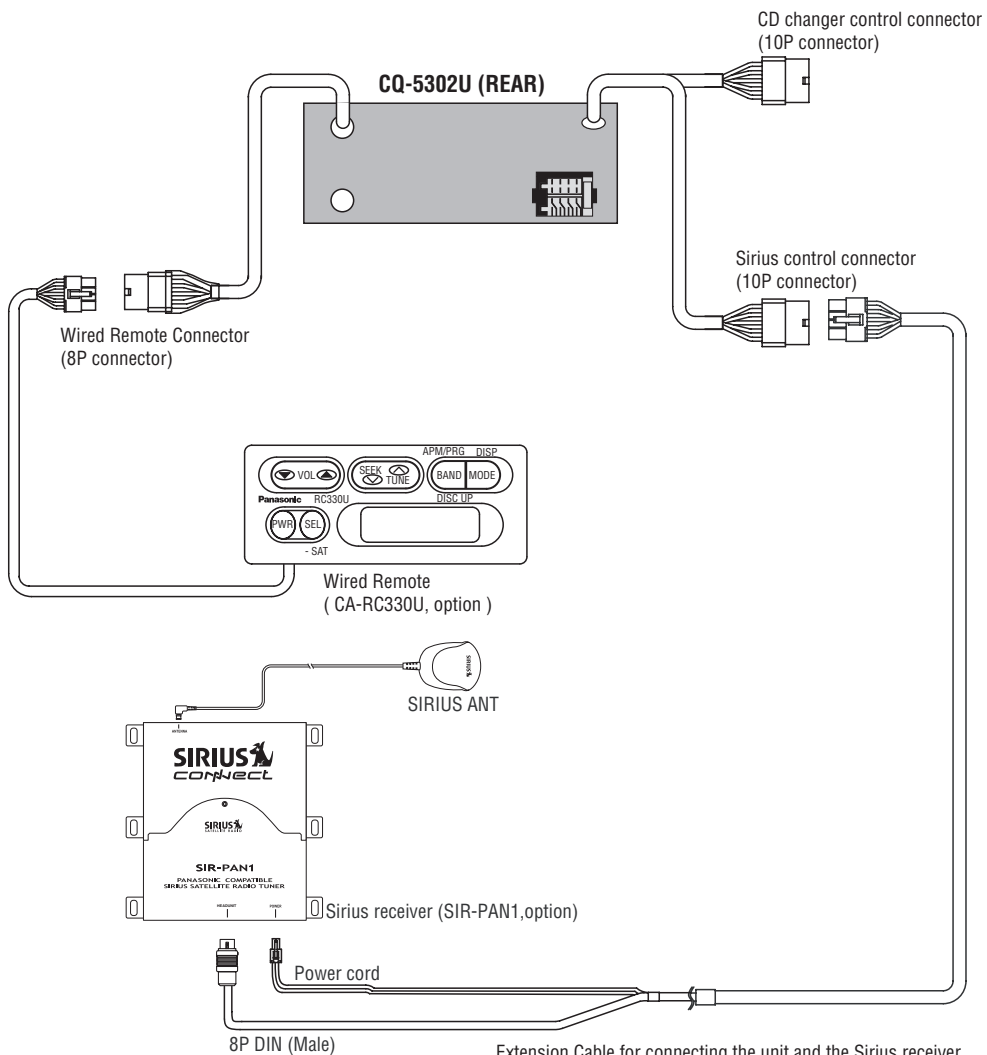

※ The Extension cable does not come along with the unit, if need, please consult your dealer.

❑ **Upgrading the system (connect a XM receiver and the wired remote.)**

Note:

For wiring, carefully read the operation instructions for the devices connected.

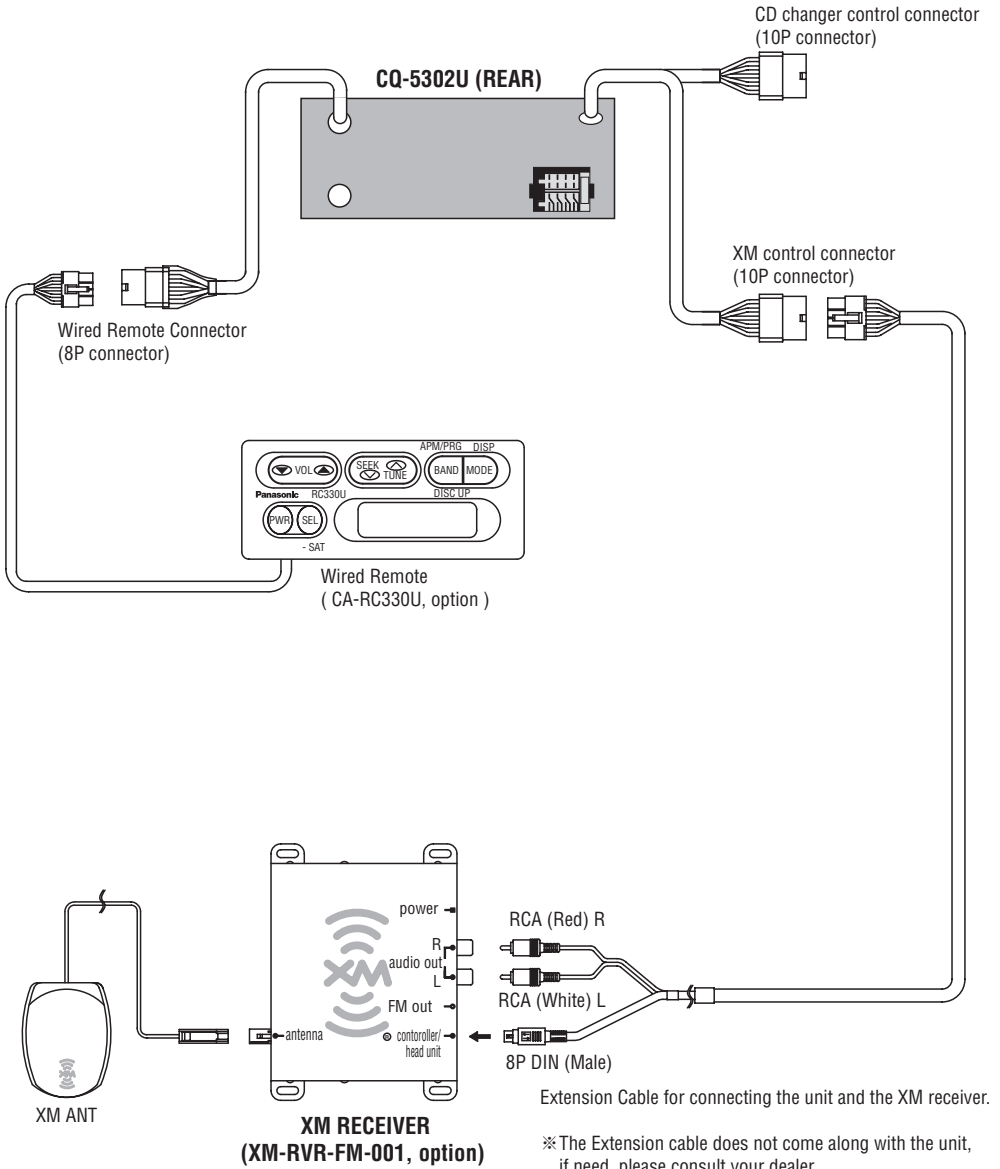

Electrical Connections (Continued)

❑ Upgrading the system (connect a CD changer and the wired remote.)

Note:

For wiring, carefully read the operation instructions for the devices connected.

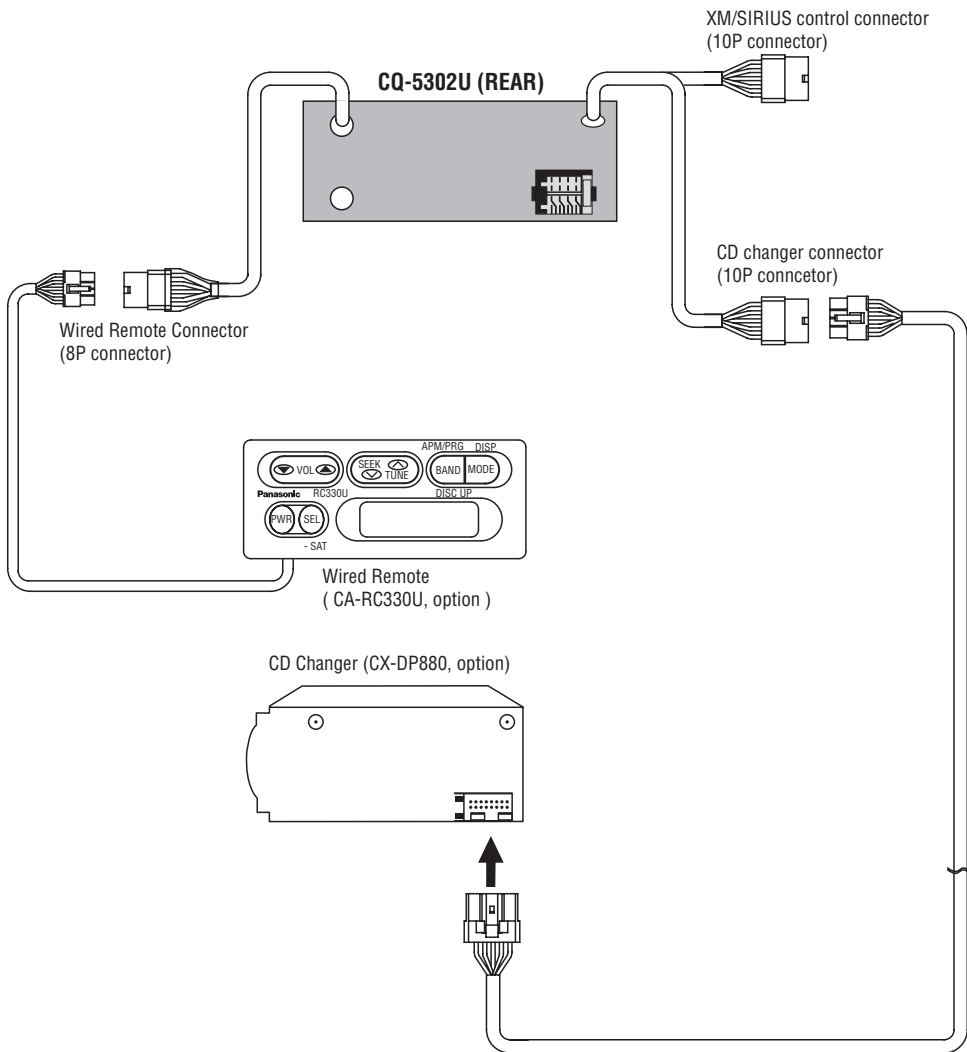

Extension Cable for connecting the unit and CD changer.

※ The Extension cable does not come along with the unit, if need, please consult your dealer.

Specifications

□ General

Power Supply:	12 V DC (11 V-16 V) test Voltage 14.4 V, Negative ground
Current consumption:	Less than 2.5 A (CD mode, 0.5 W 4-speaker)
Maximum Power Output:	37 W × 4 channels at 400 Hz, Volume Control maximum
Tone adjustment range:	
Bass:	± 12 dB at 100 Hz
Treble:	± 12 dB at 10 kHz
Power Output:	18 W per channel into 4 ohms, 40 to 30 000 Hz at 3 % THD
Suitable Speaker Impedance:	4-8 Ω
Dimensions (W × H × D):	178(W) × 50(H) × 155(D) mm {7" × 1 ¹⁵ / ₁₆ " × 6 ¹ / ₈ "}
Weight:	1.7 kg {3 lbs. 12 oz}

□ FM Stereo Radio

Frequency Range:	87.9-107.9 MHz
Useable Sensitivity:	12 dBf. (1.1 μV/ 75 Ω, S/N 30 dB)
50 dB Quieting Sensitivity:	17 dBf. (1.8 μV/ 75 Ω)
Frequency Response:	30-15 000 Hz ±3 dB
Alternate Channel Selectivity:	75 dB
Stereo Separation:	35 dB at 1 kHz
Signal/Noise Ratio:	70 dB (Mono)

□ AM Radio

Frequency range:	530 kHz–1 710 kHz
Usable sensitivity:	28 dB/μV (S/N 20 dB)

□ Weather Band Radio

Frequency range:	162.40 –162.55 MHz
Usable sensitivity:	3 dB/μV (S/N 20 dB)
Signal/Noise Ratio (40 dB/μV):	50 dB

□ CD Player

Sampling Frequency:	8 times oversampling
DA Converter:	MASH•1 bit/4 DAC System
Error Correction System:	Spot size detection method
Pick-Up Type:	3-beam
Light Source:	Semiconductor laser
Wavelength:	790 nm
Frequency Response:	20 - 20,000 Hz (±1 dB)
Signal to Noise Ratio:	85 dB
Wow and Flutter:	Below measurable limits
Channel Separation:	75 dB

Above specifications comply with EIA standards.

Power Output:
18 W RMS x 4 Channels at 4 Ω and ≤ 1%
THD+N
Signal to Noise Ratio:
85 dBA (reference: 1 W into 4 Ω)



Note: Specifications and the design are subject to modification without notice due to improvements in technology.

**Panasonic Consumer Electronics
Company, Division of Panasonic
Corporation of North America**
One Panasonic Way, Secaucus,
New Jersey 07094
<http://www.panasonic.com>